

# MODEL 2500 ECONOMINDER®

## *Service Manual*

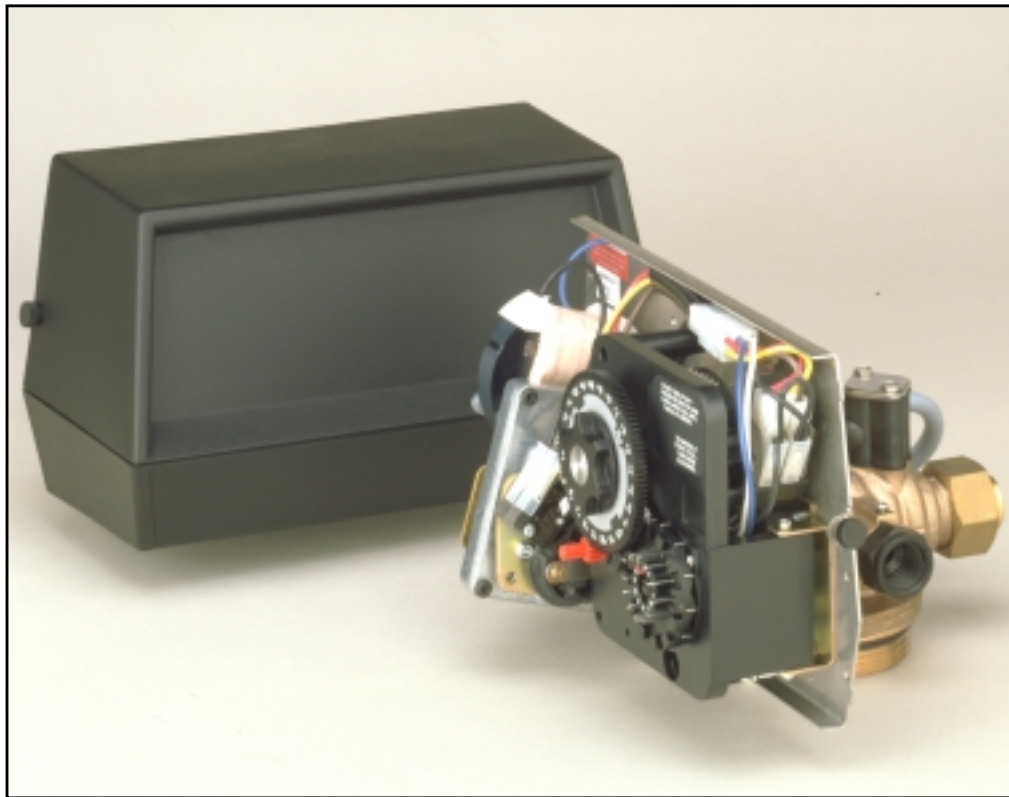

**IMPORTANT:** Fill in pertinent information on page 2 for future reference.

# MODEL 2500 ECONOMINDER®

---

## *Job Specification Sheet*

---

\* JOB NO. \_\_\_\_\_

\* MODEL NO. \_\_\_\_\_

\* WATER TEST \_\_\_\_\_

\* CAPACITY PER UNIT \_\_\_\_\_ MAX. \_\_\_\_\_ PER REGENERATION

\* MINERAL TANK SIZE DIA. \_\_\_\_\_ HEIGHT \_\_\_\_\_

\* BRINE TANK SIZE &  
SALT SETTING PER REGENERATION \_\_\_\_\_

### \* 2500 CONTROL VALVE SPECIFICATIONS

1. Type of Timer

A) Separate Time Fill

B) Rapid Rinse

2. Type of Meter (3/4")

A) \*Std. range 125 to 2,100 gal. setting

B) \* Ext. range 625 to 10,500 gal. setting

3. Meter Gallon Setting \_\_\_\_\_ gal.

4. Regeneration Program Setting (see page 5)

A) Backwash \_\_\_\_\_ min.

B) Brine & Slow Rinse \_\_\_\_\_ min.

C) Rapid Rinse \_\_\_\_\_ min.

D) Brine Tank Refill \_\_\_\_\_ min.

5. Drain Line Flow Control \_\_\_\_\_ gpm

6. Brine Refill Rate \_\_\_\_\_ gpm

7. Injector Size \_\_\_\_\_

# MODEL 2500 ECONOMINDER®

---

## *Installation Instructions*

---

The water softener should be installed with the inlet, outlet and drain connections made in accordance with manufacturer's recommendations and to meet applicable plumbing codes.

1. Remove control box cover.
2. Make "Time of Day" setting and set "Program Wheel." (See time control instructions). Rotate program wheel counter clockwise until it stops at regeneration position.
3. Observe regeneration cycle settings. (These are factory preset and need no adjustment).
4. Add three inches of water to brine tank.
5. NOTE: To set the control to the various positions noted below — turn the manual regeneration knob slowly in a clockwise direction until the drive motor runs and positions the valve drive shaft (located in the lower center of the control box.)

### **Control Valve Positions**

Service — Drive shaft out

Backwash — Drive shaft in

Brine and Rinse — Drive shaft 1/2 way out

Brine Tank Fill — Drive shaft out but brine cam holds brine valve stem in.

6. Run water through softener with control in service position for at least three (3) minutes to settle bed.
7. Position valve to backwash and check to make sure that drain line flow remains steady for ten (10) minutes.
8. Position valve to brine tank fill and check to see if tank is filling.
9. Position valve to brine position and check suction.
10. Position valve to start of brine tank fill cycle. Brine valve drive cam will hold valve in at this position to fill the brine tank for the first regeneration.
11. Replace control box cover.
12. Check power cord connection. (Note: Make sure control is plugged into a non-interrupted electrical circuit).
13. Put salt in brine tank. (Do not use granulated salt.)

# MODEL 2500 ECONOMINDER®

## Demand Regeneration Control

### Start-up Procedure

#### Typical Residential Application

To program, just set the time, set the hardness and it automatically monitors system needs and regenerates only when necessary. To set time of day press red time set button and turn 24 hour gear until present time of day is opposite "time of day arrow." Set program wheel by lifting the "people" dial and rotating it so that the number of people in the household is aligned with the grains per gallon water hardness scale. Release the dial and check for firm engagement at setting. (This method will provide reserve capacity based on 75 gallons per person.)

#### Optional Programming Procedure

Calculate the gallon capacity of the system, subtract the necessary reserve requirement and set the gallons available opposite the small white dot on the program wheel. Note, drawing shows 850 gallon setting. The capacity (gallons) arrow denotes remaining gallons exclusive of fixed reserve.

**ie: Calculated gallon capacity of system is 1000 gallons. Number of people using the system is 4.75 gallons per person is used for a safe reserve capacity - 300 gallons reserve = 700 gallons available. This number should be set opposite the white dot on program wheel.**

#### How To Set The Time Of Day:

Press and hold the red button in to disengage the drive gear.

Turn the large gear until the actual time of day is at the time of day pointer.

Release the red button to again engage the drive gear.

#### How To Manually Regenerate Your Water Conditioner At Any Time:

Turn the manual regeneration knob clockwise.

This slight movement of the manual regeneration knob engages the program wheel and starts the regeneration program.

The black center knob will make one revolution in the following approximately three hours and stop in the position shown in the drawing.

Even though it takes three hours for this center knob to complete one revolution, the regeneration cycle of your unit might be set for only one half of this time.

In any event, conditioned water may be drawn after rinse water stops flowing from the water conditioner drain line.

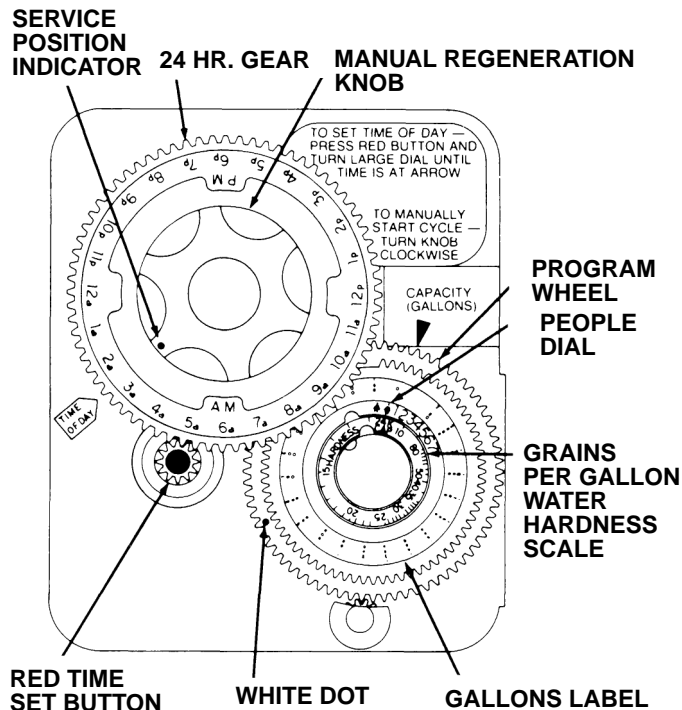

### IMPORTANT!

**SALT LEVEL MUST ALWAYS  
BE ABOVE WATER LEVEL  
IN BRINE TANK.**

# MODEL 2500 ECONOMINDER®

## Regeneration Cycle Program Setting Procedure

### How to Set The Regeneration Cycle Program:

The regeneration cycle program on your water conditioner has been factory preset, however, portions of the cycle or program may be lengthened or shortened in time to suit local conditions.

**If unit has a meter, disconnect meter cable from meter at this time.**

To expose cycle program wheel, grasp timer in upper left-hand corner and pull, releasing snap retainer and swinging timer to the right. (**meter cable must be disconnected**)

To change the regeneration cycle program, the program wheel must be removed. Grasp program wheel and squeeze protruding lugs towards center, lift program wheel off timer. (Switch arms may require movement to facilitate removal).

### How To Change The Length Of The Backwash Time:

The program wheel as shown in the drawing is in the service position. As you look at the numbered side of the program wheel, the group of pins starting at zero determines the length of time your unit will backwash.

**FOR EXAMPLE:** If there are six pins in this section, the time of backwash will be 12 min. (2 min. per pin). To change the length of backwash time, add or remove pins as required. The number of pins times two equals the backwash time in minutes.

### How To Change The Length Of Brine And Rinse Time:

The group of holes between the last pin in the backwash section and the second group of pins determines the length of time that your unit will brine and rinse. (2 min. per hole.)

To change the length of brine and rinse time, move the rapid rinse group of pins to give more or fewer holes in the brine and rinse section. Number of holes times two equals brine and rinse time in minutes.

### How to Change The Length Of Brine Tank Refill Separate From Rapid Rinse: STF Black Cams

The second group of pins on the program wheel determines the length of time that your water conditioner will rapid rinse. (2 min. per pin.)

To change the length of rapid rinse time, add or remove pins at the higher numbered end of this section as required. The number of pins times two equals the rapid rinse time in minutes.

### How To Change The Length Of Brine Tank Refill Time:

The second group of holes on the program wheel determines the length of time that your water conditioner will refill the brine tank. (2 min. per hole.)

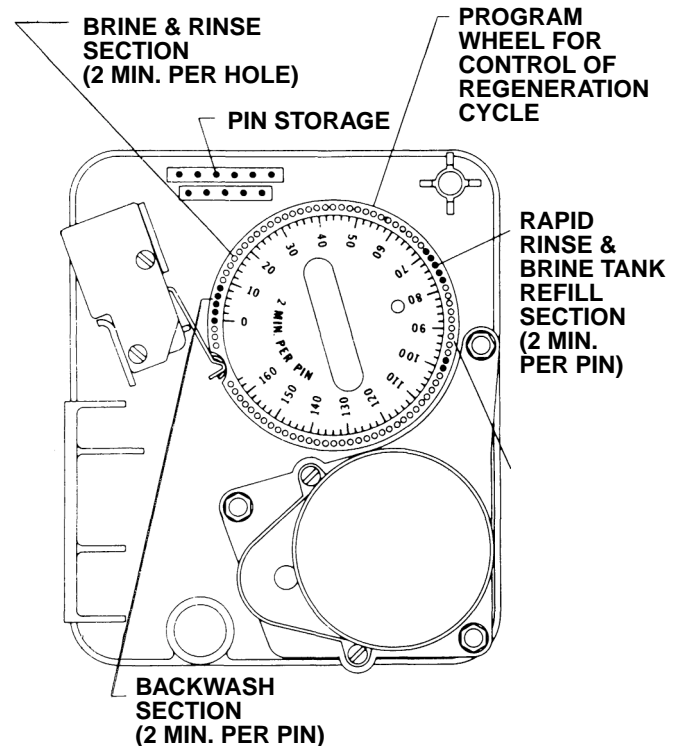

To change the length of refill time, move the two pins at the end of the second group of holes as required.

The regeneration cycle is complete when the outer micro-switch is tripped by the two pin set at end of the brine tank refill section. The program wheel, however, will continue to rotate until the inner micro-switch drops into the notch on the program wheel.

### How To Change The Length Of Rapid Rinse And Brine Tank Fill Time: RR White Cams

The second group of pins on the program wheel determines the length of time that your water conditioner will rapid rinse and brine tank fill. (2 min. per pin.)

To change the length of rapid rinse and brine tank fill time, add or remove pins at the higher numbered end of this section as required. The number of pins times two equals the rapid rinse and brine tank fill time in minutes.

The regeneration cycle is complete when the outer micro-switch drops off the last pin in the rapid rinse and brine tank fill group of pins. The program wheel, however, will continue to rotate until the inner micro-switch drops into the notch on the program wheel.

**Return timer to closed position engaging snap retainer in back plate. Make certain all electrical wires locate above snap retainer post and the meter cable slides through the backplate and does not bind. Reconnect meter cable.**

# MODEL 2500 ECONOMINDER®

## Water Conditioner Flow Diagrams

### 1 SERVICE POSITION

Hard water enters unit at valve inlet and flows down thru the mineral in the mineral tank. Conditioned water enters center tube thru the bottom distributor then — flows up thru the center tube — around the piston and out the top outlet of the valve.

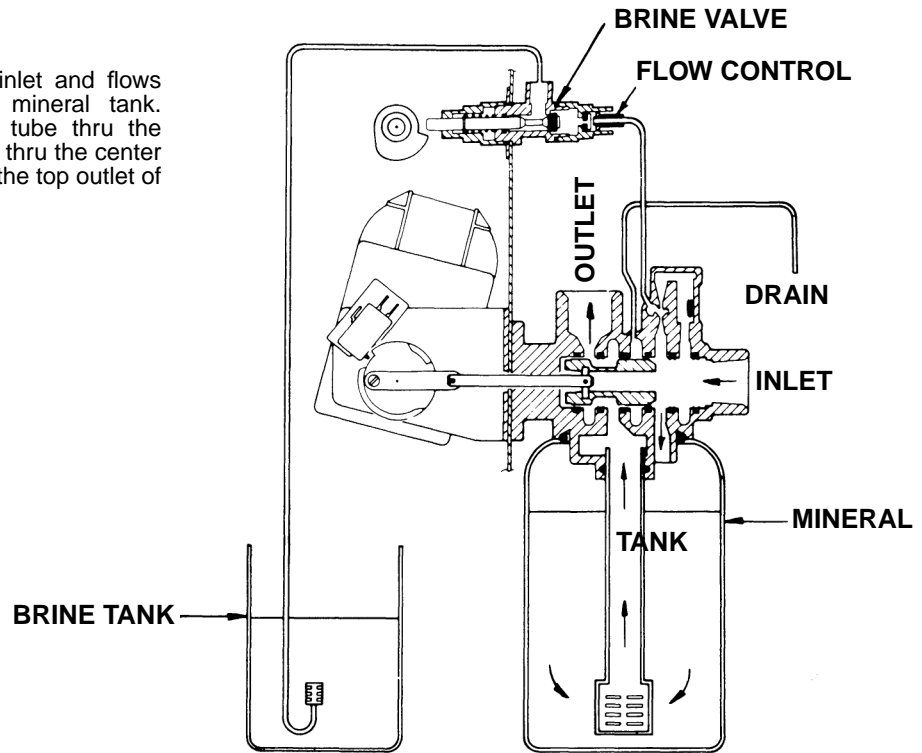

### 2 BACKWASH POSITION

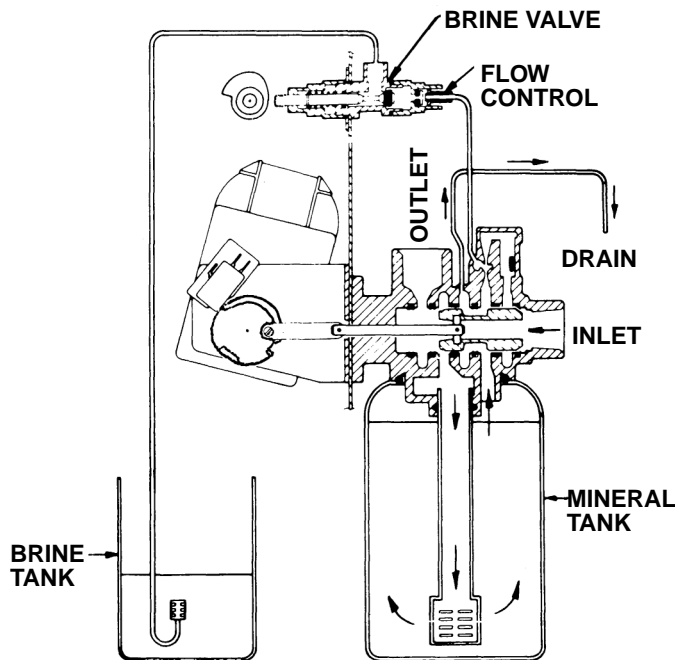

Hard water enters unit at valve inlet — flows thru piston — down center tube — thru bottom distributor and up thru the mineral — around the piston and out the drain line.

### 3 BRINE POSITION

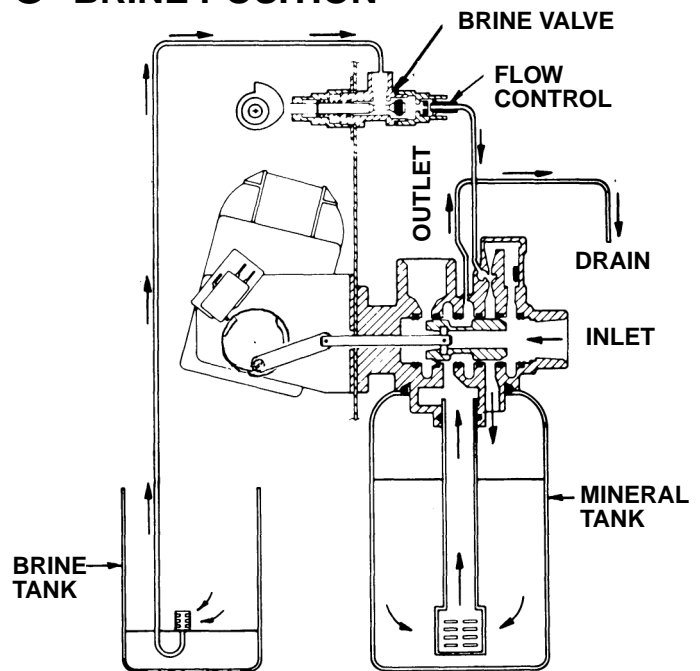

Hard water enters unit at valve inlet — flows up into injector housing and down thru nozzle and orifice to draw brine from the brine tank — brine flows down thru mineral and enters the center tube thru bottom distributor flows up thru center tube — around the piston and out thru the drain line.

# MODEL 2500 ECONOMINDER®

## Water Conditioner Flow Diagrams (Cont'd.)

### 4 SLOW RINSE POSITION

Hard water enters unit at valve inlet — flows up into injector housing and down thru nozzle and orifice — around the piston — down thru mineral enters center tube thru bottom distributor — flows up thru center tube — around piston and out thru the drain line.

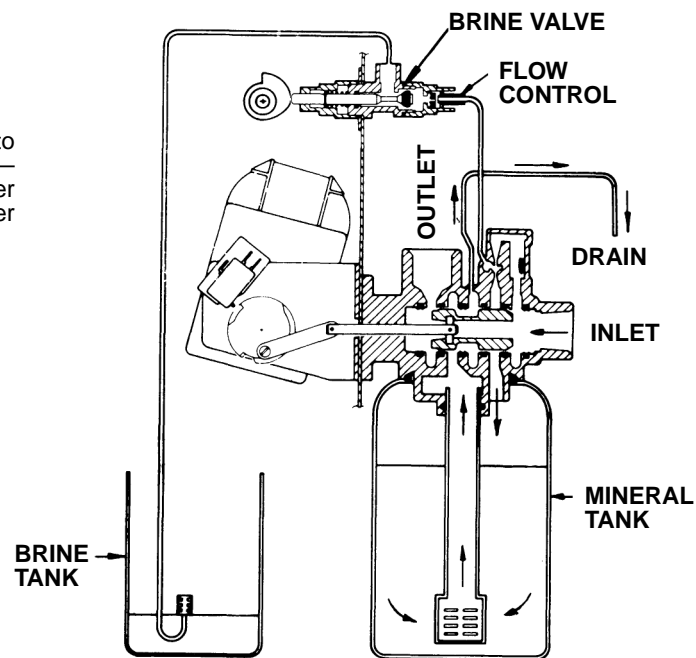

### 5 RAPID RINSE & BRINE TANK FILL

Hard water enters unit at valve inlet — flows up thru injector housing and thru brine valve to fill brine tank — hard water also flows directly from inlet down thru mineral into center tube bottom distributor and up thru center tube — around piston and out thru the drain line.

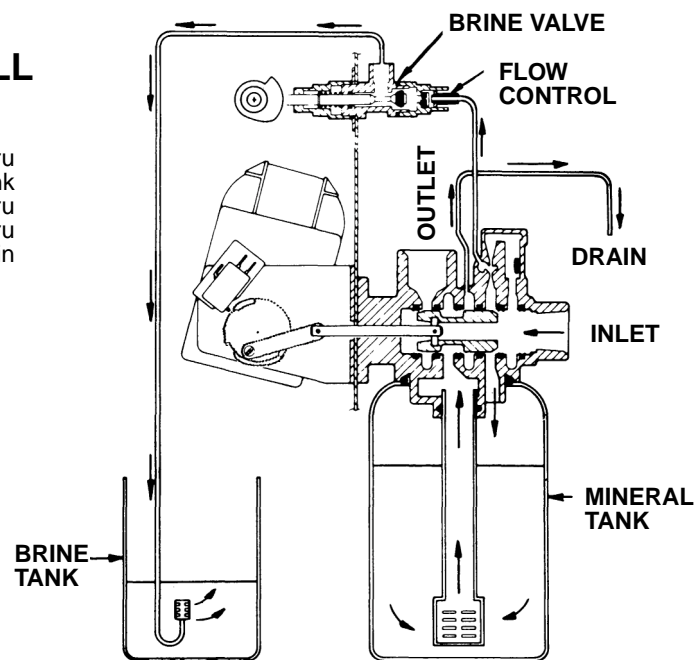

# MODEL 2500 ECONOMINDER®

## Control Valve Drive Assembly

(See opposite page for parts list)

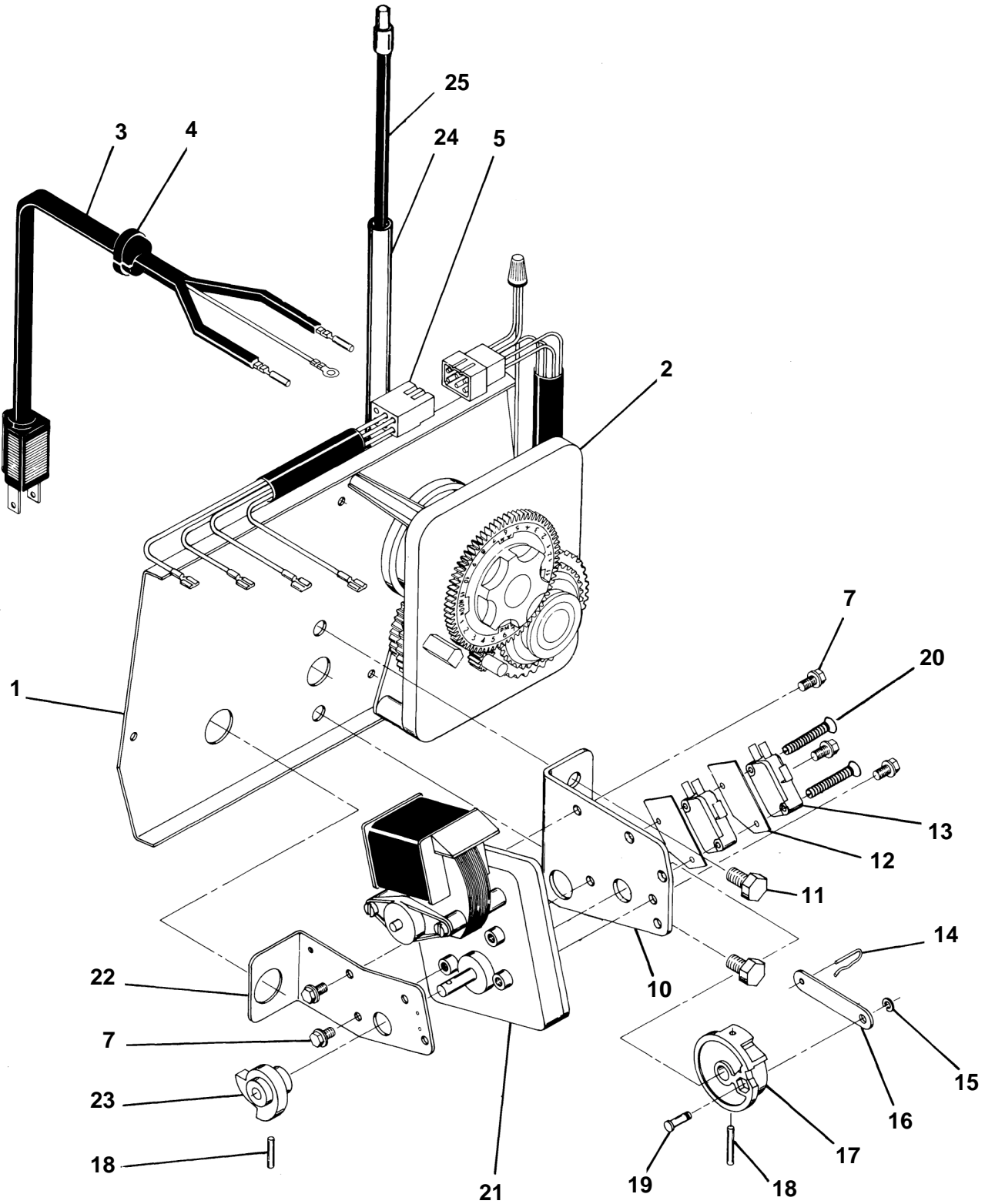



# MODEL 2500 ECONOMINDER®

## Control Valve Drive Assembly (Cont'd.)

### Parts List

Item No.	Quantity	Part No.	Description
1	1	14884	Back Plate - Stainless Steel
	1	11209	Back Plate - Slant Front (not shown)
2	1		3200, Metered Unit Timer
3	1	11838	Power Cord
4	1	13547	Strain Relief
5	1	11667	Wire Harness
6			Not Assigned
7	5	10872	Screw - Motor Mounting
8			Not Assigned
9			Not Assigned
10	1	10774	Bracket - Motor Mounting
11	2	10231	Screw - Drive Mounting
12	2	10302	Insulator
13	2	10218	Switch
14	1	10909	Connecting Link Pin
15	1	10250	Retaining Ring
16	1	10621	Connecting Link
17	1	12576	Drive Cam - STF (Black)
	1	12102	Drive Cam - RR (White)
18	2	10338	Roll Pin
19	1	13366	Drive Bearing
20	2	14923	Screw - Switch Mounting
21	1	10769	Motor
22	1	11826	Bracket - Brine Valve Side
23	1	12777	Brine Valve Cam - STF (Black) - (shown)
	1	10815	Brine Valve Cam - RR (White)
24	1	15625	Meter Cable Guide Ass'y
25	1	14968	Meter Cable
26	2	10300	Screw - Timer Mounting (not shown)
27	1	13741	Hole Plug (not shown)
28	1	17904	Hole Plug (not shown)

#### COVER MOUNTING HARDWARE

Stainless Steel

Back Plate . . . . 2 . . . . . 19367 . . . . . Screw

Slant Front

Back Plate . . . . 4 . . . . . 10300 . . . . . Screw

# MODEL 2500 ECONOMINDER®

## Control Valve Assembly

(See opposite page for parts list)

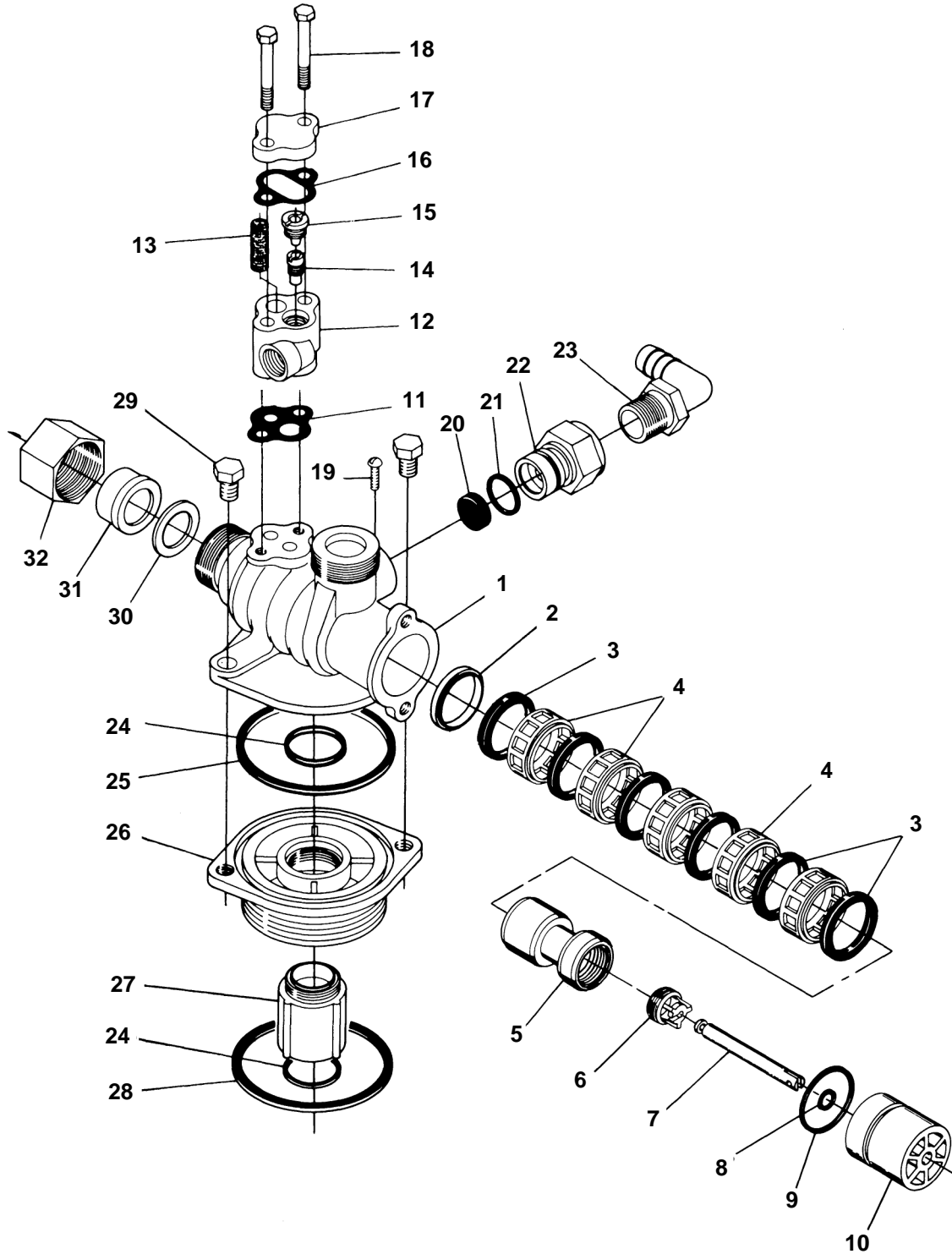

# MODEL 2500 ECONOMINDER®

## Control Valve Assembly (Cont'd.)

### Parts List

Item No.	Quantity	Part No.	Description
1.	1	11212	Valve Body
2.	1	10757	End Spacer
	1	10757B	End Spacer, Hot Water
3.	6	10545	Seal Ring
	6	17773	Silicone
4.	5	11451	Spacer
	5	16589	Spacer, Hot Water
5.	1	15168	Piston
6.	1	14309	Piston Rod Retainer
	1	16590	Piston Rod Retainer, Hot Water
7.	1	14452	Piston Rod
8.	1	10209	Seal Quad Ring
	1	10209-01	Seal Quad Ring, Hot Water
9.	1	40078	Seal O-Ring - End Plug
10.	1	10598	End Plug Assembly
	1	10598-01	End Plug Assembly, Hot Water
11.	1	11475	Injector Body Gasket
12.	1	17776	Injector Body - Plastic
	1	11483	Injector Body - Brass
13.	1	10227	Injector Screen
14.	1	10914	Injector Throat (Specify Size)
	1	10226	Injector Throat, Stainless Steel (Specify Size)
15.	1	10913	Injector Nozzle (Specify Size)
	1	10225	Injector Nozzle, Stainless Steel (Specify Size)
16.	1	10229	Injector Cover Gasket
17.	1	10228	Injector Cover (Brass Body)
	1	11893	Injector Cover (Plastic Body)
18.	1	10692	Injector Body Screw
19.	1	11180	Flow Control Retainer Screw
20.	1		Flow Control Washer (Specify Flow Rate in G.P.M.)
21.	1	11183	Seal O-Ring
22.	1	11385	Flow Control Housing
	1	11385-03	Flow Control Housing, Brass
	1	11385-13	Flow Control Housing, Brass Bored
23.	1	12338	1/2 Pipe x 1/2 Hose x 90° Drain Fitting
24.	2	10244	Inside Tube O-Ring
25.	1	11208	Seal O-Ring
26.	1	11143	Valve Body Adapter (For 2 1/4 - 16 Thd)
	1	12341	Valve Body Adapter (For 2 1/2 - 8 Thd)
27.	1	11966	Distributor Tube Pilot Assembly 13/16"
	1	14673	Distributor Tube Pilot Assembly 13/16", Hot Water
28.	1	10207	Tank O-Ring (For 2 1/4 - 16 Thd)
	1	10381	Tank O-Ring (For 2 1/2 - 8 Thd)
	1	12570	Tank O-Ring (Park)
29.	2	11224	Hex Head Cap Screw
30.	2	11206	Fitting Gasket
31.	2	11205	Tube Fitting Special
32.	2	11207	Special Nut
NOTE: For Flat Cap/Backwash Filter Valve - Loss Items 12 thru 18.			
33.	1	11893	Cap
34.	2	15137	Screw Flat Cap

# MODEL 2500 ECONOMINDER®

## Timer Assembly

(See opposite page for parts list)

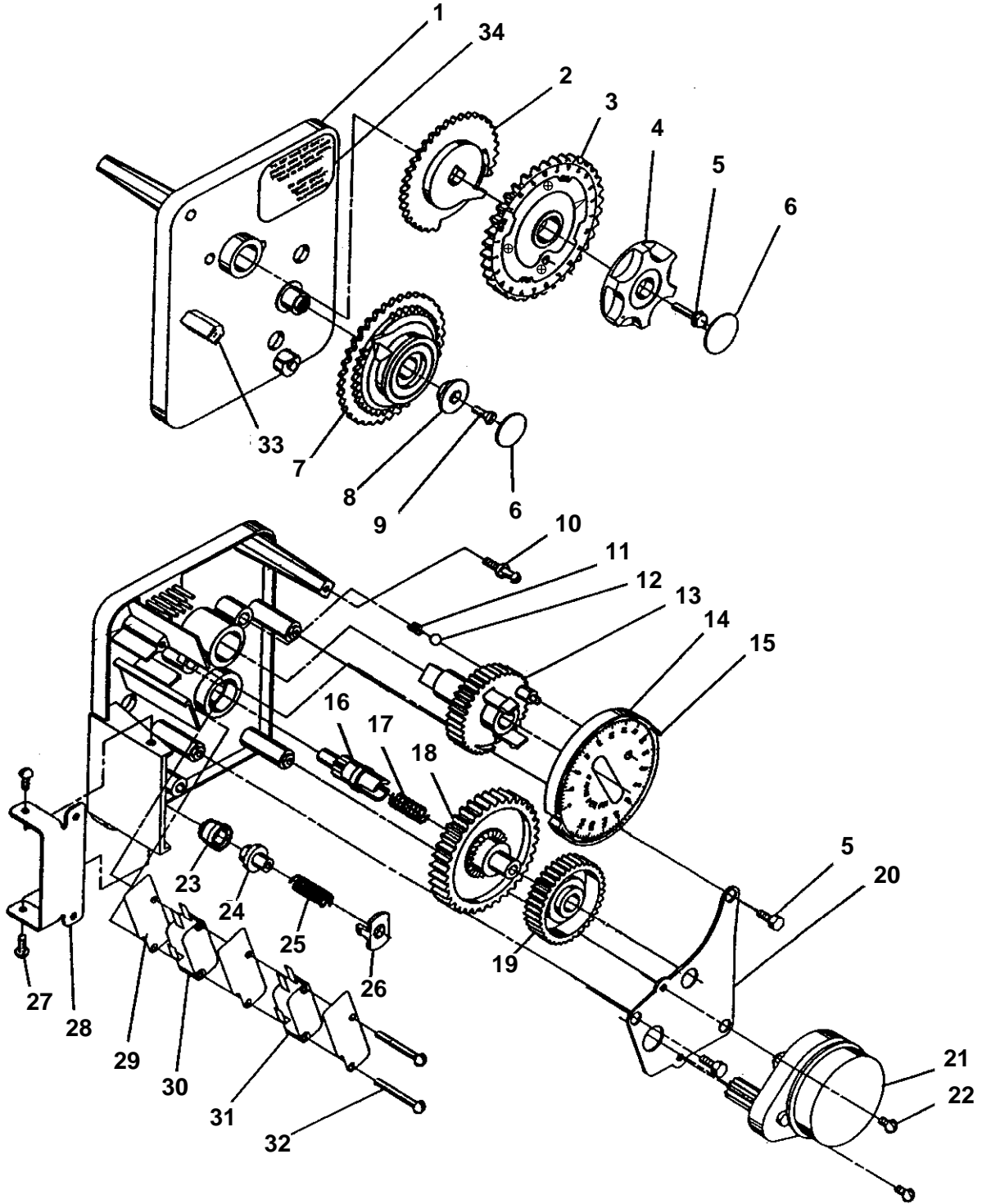

# MODEL 2500 ECONOMINDER®

## Timer Assembly (Cont'd.)

### Parts List

Item No.	Quantity	Part No.	Description
1.....	1 .....	13870-01.....	Timer Housing Assembly
2.....	1 .....	13802 .....	Cycle Actuator Gear
3.....	1 .....	40096-24.....	24 Hour Gear Assembly, 12 Midnight
		40096-02.....	24 Hour Gear Assembly, 2 a.m.
4.....	1 .....	13886-01.....	Knob
5.....	4 .....	13296 .....	Screw - Timer Knob and Motor Plate Mtg.
6.....	2 .....	11999 .....	Button Decal
7.....	1 .....	60405-15.....	Program Wheel Assy. (Specify Hardness Capacity)
8.....	1 .....	13806 .....	Program Wheel Retainer
9.....	1 .....	13748 .....	Screw - Program Wheel Mtg.
10.....	1 .....	14265 .....	Spring Clip
11.....	1 .....	15424 .....	Spring - Detent
12.....	1 .....	15066 .....	Ball - 1/4 in. Dia.
13.....	1 .....	13911 .....	Main Drive Gear
14.....	1 .....	19210 .....	Program Wheel
15.....	21 .....	15493 .....	Roll Pin
16.....	1 .....	13018 .....	Idler Shaft
17.....	1 .....	13312 .....	Spring - Idler
18.....	1 .....	13017 .....	Idler Gear
19.....	1 .....	13164 .....	Drive Gear
20.....	1 .....	13887 .....	Motor Mounting Plate
21.....	1 .....	18743 .....	Motor - 120V., 60 Hz.
		19659 .....	Motor - 24V., 60 Hz.
22.....	2 .....	13278 .....	Screw, Motor Mounting
23.....	1 .....	13830 .....	Drive Pinion - Program Wheel
24.....	1 .....	13831 .....	Clutch - Drive Pinion
25.....	1 .....	14276 .....	Spring
26.....	1 .....	14253 .....	Spring Retainer
27.....	3 .....	11384 .....	Screw - Timer Hinge and Ground Wire
28.....	1 .....	13881 .....	Hinge Bracket
29.....	3 .....	14087 .....	Insulator
30.....	1 .....	10896 .....	Switch
31.....	1 .....	15320 .....	Switch
32.....	2 .....	11413 .....	Screw - Switch Mounting
33.....	1 .....	14007 .....	Decal - Time of Day
34.....	1 .....	14045 .....	Decal - Instructions
Not Shown....	1 .....	13902 .....	Harness
Not Shown....	2 .....	12681 .....	Wire Connector
Not Shown....	1 .....	15354-01.....	Ground Wire 17748-01 F.E.

# MODEL 2500 ECONOMINDER®

## Meter Assembly

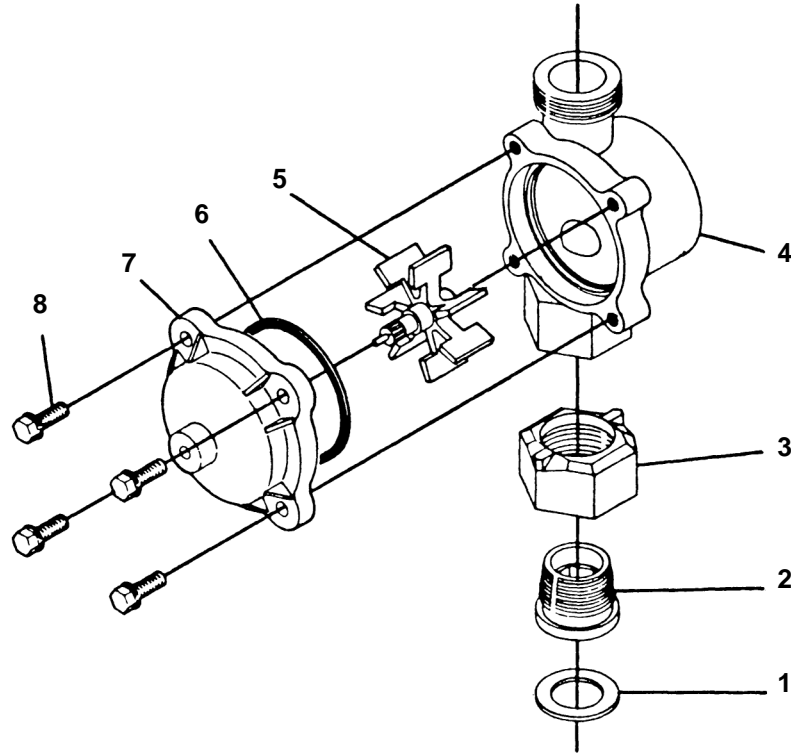

### PARTS LIST

Item No.	Quantity	Part No.	Description
1	1	11206	Fitting Gasket
2	1	13942	Nut Retainer
3	1	11207	Special Nut
4	1	14083	Meter Body Assembly
5	1	13509	Impeller
		13509-01	Impeller, Hot Water
6	1	13847	O-Ring - Meter Cover Assembly
7	1	14038	Meter Cover Assembly
	1	15218	Meter Cover Assembly, Brass
	1	15150	Meter Cover Assembly Extended Range (not shown)
	1	15237	Meter Cover Assembly Extended Range (not shown), Brass
8	4	12473	Screw - Meter Cover Assembly

# MODEL 2500 ECONOMINDER®

## 1600 Series Brine System Assembly

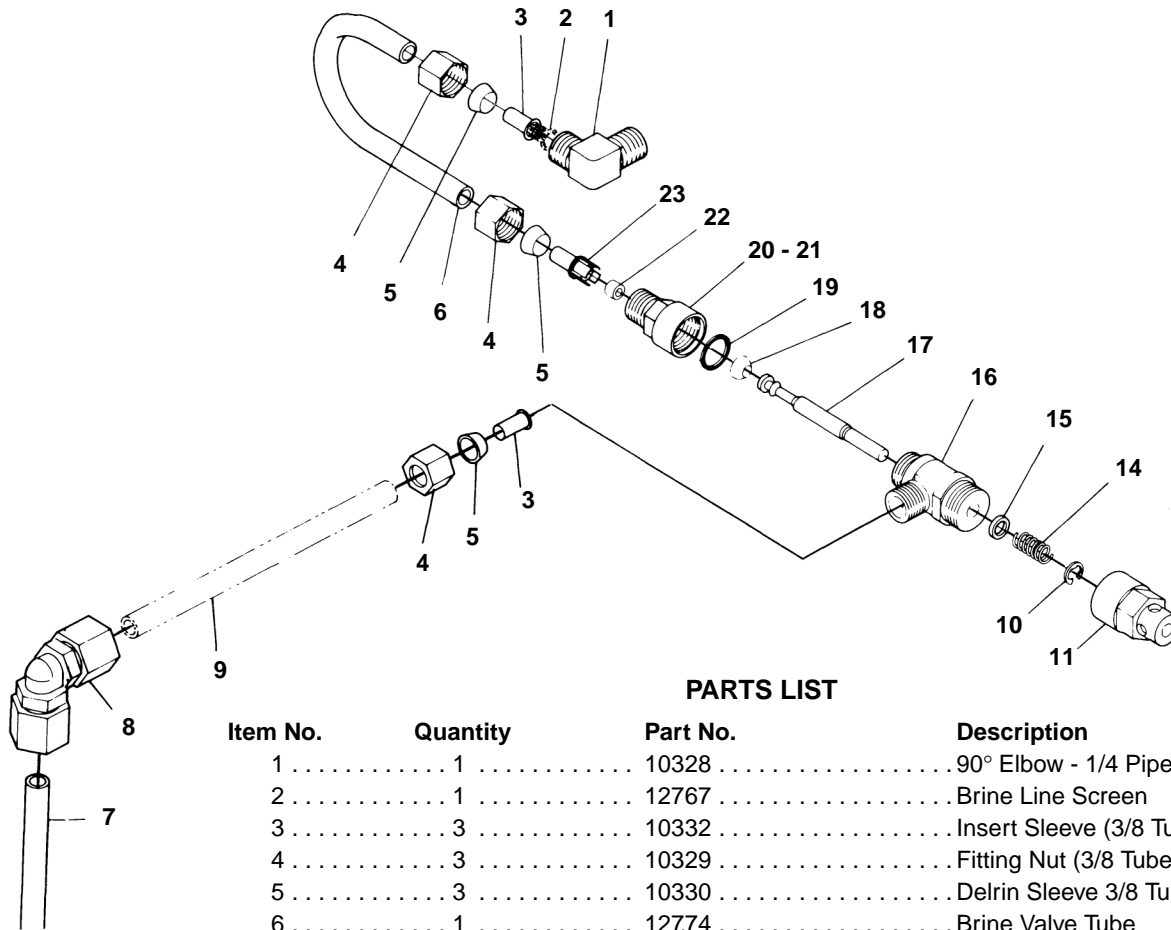

### PARTS LIST

Item No.	Quantity	Part No.	Description
1	1	10328	90° Elbow - 1/4 Pipe Thd. to 3/8 Tube
2	1	12767	Brine Line Screen
3	3	10332	Insert Sleeve (3/8 Tube)
4	3	10329	Fitting Nut (3/8 Tube)
5	3	10330	Delrin Sleeve 3/8 Tube)
6	1	12774	Brine Valve Tube
7	1	60002	Air Check Assembly
8	1	12794	90° Elbow - 3/8 Tube to 3/8 Tube
9	1	Not Supplied	Brine Line Tube (3/8 Flexible Tube)
10	1	10250	Retaining Ring
11	1	11749	Stem Guide
12			Not Assigned
13			Not Assigned
14	1	10249	Brine Valve Spring
15	1	12550	Quad Ring
16	1	12748	Brine Valve Body
17	1	12552	Brine Valve Stem
18	1	12626	Brine Valve Seat
19	1	11982	O-Ring
*20	1	12747	Flow Control Fitting
*21	1		Flow Control Label - (Specify Flow Rate)
*22	1		Flow Control Washer - (Specify Flow Rate)
*23	1	12098	Flow Control Retainer

\*These Parts Are Furnished Assembled Together As A Brine Line Flow Control (BLFC).

# MODEL 2500 ECONOMINDER®

## Service Instructions

PROBLEM	CAUSE	CORRECTION
1. Softener fails to regenerate.	A. Electrical service to unit has been interrupted. B. Timer is defective. C. Power failure.	A. Assure permanent electrical service (check fuse, plug, pull chain or switch). B. Replace timer. C. Reset time of day.
2. Hard water.	A. By-pass valve is open. B. No salt in brine tank. C. Injector screen plugged. D. Insufficient water flowing into brine tank. E. Hot water tank hardness. F. Leak at distributor tube. G. Internal valve leak.	A. Close by-pass valve. B. Add salt to brine tank and maintain salt level above water level. C. Clean injector screen. D. Check brine tank fill time and clean brine line flow control if plugged. E. Repeated flushings of the hot water tank is required. F. Make sure distributor tube is not cracked. Check O-ring and tube pilot. G. Replace seals and spacers and/or piston.
3. Unit used too much salt.	A. Improper salt setting. B. Excessive water in brine tank.	A. Check salt usage and salt setting. B. See problem no. 7
4. Loss of water pressure.	A. Iron buildup in line to water conditioner. B. Iron buildup in water conditioner. C. Inlet of control plugged due to foreign material broken loose from pipes by recent work done on plumbing system.	A. Clean line to water conditioner. B. Clean control and add mineral cleaner to mineral bed. Increase frequency of regeneration. C. Remove piston and clean control.
5. Loss of mineral through drain line.	A. Air in water system.	A. Assure that well system has proper air eliminator control. Check for dry well condition.
6. Iron in conditioned water.	A. Fouled mineral bed.	A. Check backwash, brine draw and brine tank fill. Increase frequency of regeneration. Increase backwash time.



# MODEL 2500 ECONOMINDER®

## Service Instructions (Cont'd.)

PROBLEM	CAUSE	CORRECTION
7. Excessive water in brine tank.	A. Plugged drain line flow control. B. Plugged injector system. C. Timer not cycling. D. Foreign material in brine valve. E. Foreign material in brine line flow control.	A. Clean flow control. B. Clean injector and screen. C. Replace timer. D. Replace brine valve seat and clean valve. E. Clean brine line flow control.
8. Softener fails to draw brine.	A. Drain line flow control is plugged. B. Injector is plugged. C. Injector screen plugged. D. Line pressure is too low. E. Internal control leak.	A. Clean drain line flow control. B. Clean injector. C. Clean screen. D. Increase line pressure to 20 P.S.I. E. Change seals, spacers and piston assembly.
9. Control cycles continuously.	A. Broken or shorted switch.	A. Determine if switch or timer is faulty and replace it, or replace complete power head.
10. Drain flows continuously.	A. Valve is not programming correctly. B. Foreign material in control. C. Internal control leak.	A. Check timer program and positioning of control. Replace power head assembly if not positioning properly. B. Remove power head assembly and inspect bore. Remove foreign material and check control in various regeneration positions. C. Replace seals and piston assembly.

### General Service Hints For Meter Control

#### Problem: Softener Delivers Hard Water.

Cause could be that . . . Reserve Capacity Has Been Exceeded.

**Correction:** Check salt dosage requirements and reset program wheel to provide additional reserve.

Cause could be that . . . Program Wheel Is Not Rotating With Meter Output.

**Correction:** Pull cable out of meter cover and rotate manually. Program wheel must move without binding and clutch must give positive clicks when program wheel strikes regeneration stop. If it does not, replace timer.

Cause could be that . . . Meter Is Not Measuring Flow.

**Correction:** Check output by observing rotation of small gear on front of timer (Note — program wheel must not be against regeneration stop for this check). Each tooth to tooth is approximately 30 gallons. If not performing properly, replace meter.

# MODEL 2500 ECONOMINDER®

## Seal and Spacer Replacement

1. Remove electrical plug from outlet, turn off water supply to valve and relieve water pressure.
2. Remove control box cover.
3. Disconnect the brine line, from the injector housing to the brine valve (if your unit has timed brine tank fill).
4. Remove the two capscrews that hold the back plate to the valve.
5. Grasp the back plate on both sides and slowly pull end plug and piston assembly out of the valve body, (see Fig. 1) and lay aside.

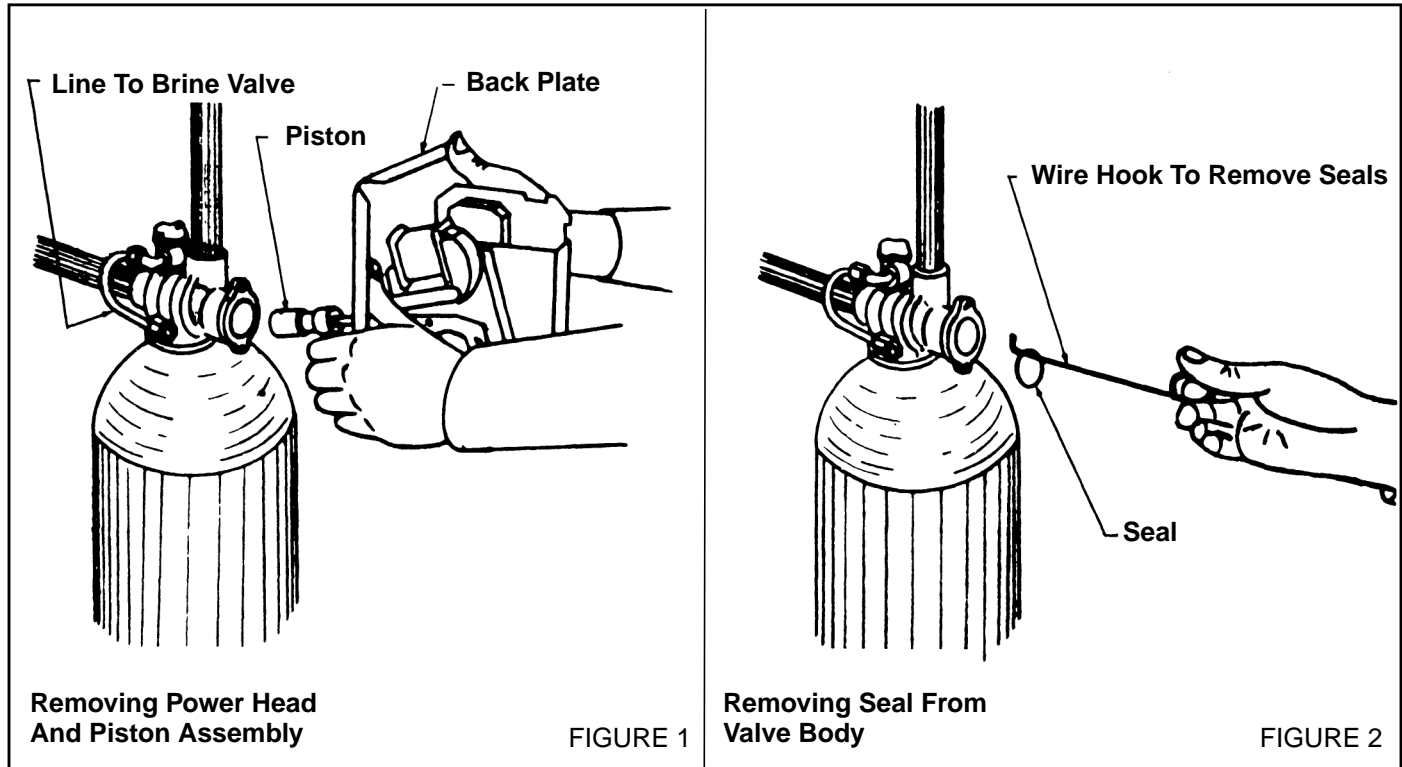

6. Remove the seal first using the wire hook with the finger loop (see Fig. 2).
7. The spacer tool (use only for removing the spacers) has three retractable pins, retained by a rubber ring, at one end; they are retracted or pushed out by pulling or pushing the center button on the opposite end.
8. Insert the pin end of the spacer tool into the valve body with the pins retracted (button pulled back). Push the tool tight against the spacer and push the button in, (see Fig. 3). When the button is pushed in, the pins are pushed out to engage the 1/4 dia. holes in the spacer. Remove the tool from the valve body. The spacer will be on the end. Pull the center button back, the pins will be retracted and the spacer can be removed from the spacer tool.

# MODEL 2500 ECONOMINDER®

## Seal and Spacer Replacement (Cont'd.)

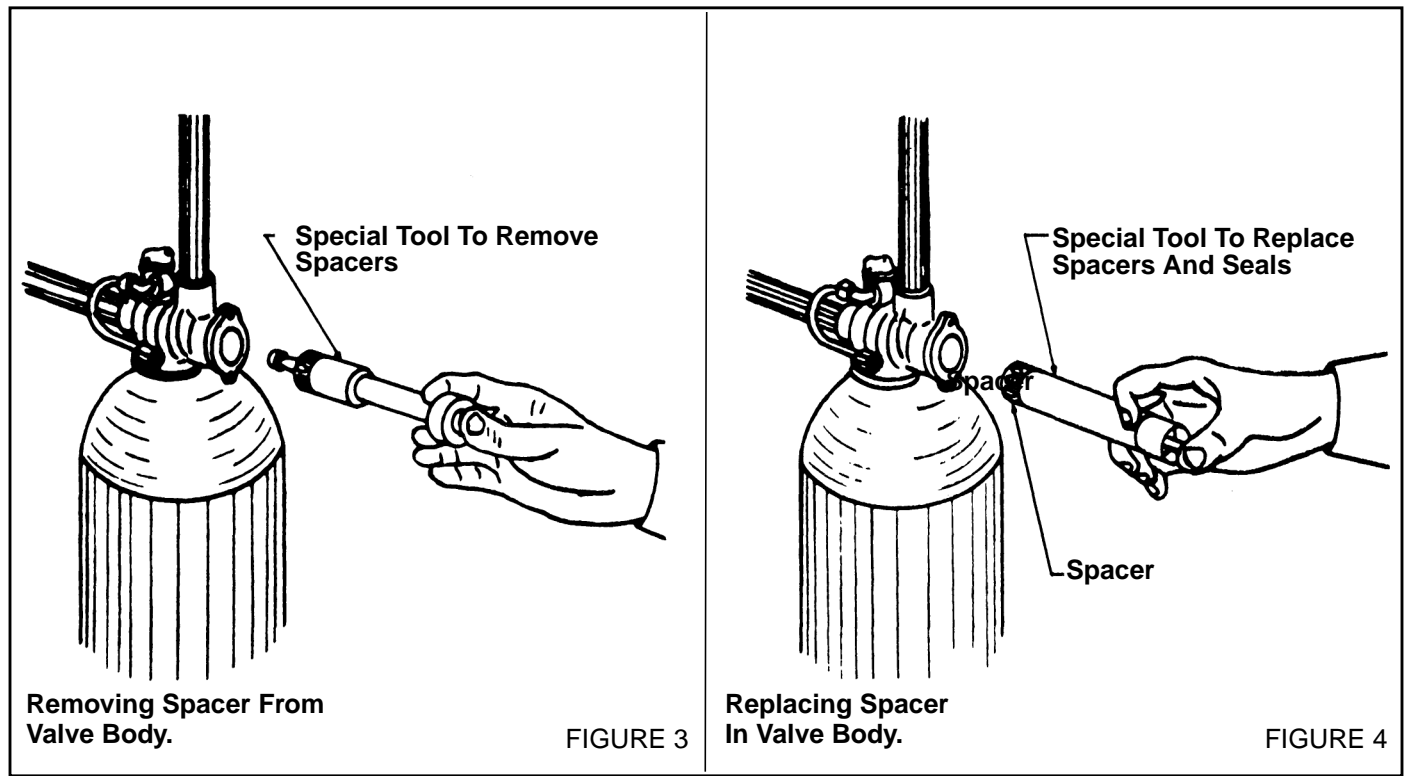

9. Alternately remove the remaining seals and spacers in accordance with steps No. 6 and 8.
10. The last or end spacer does not have any holes for the pins of the spacer tool to engage, therefore if the end spacer does not come out on the first try, try again using the wire hook with the finger loop.
11. To replace seals, spacers and end ring use special tool with the brass sleeve on one end. This is a double-purpose tool. (See Fig. 4.) The male end acts as a pilot to hold the spacers as they are pushed into the valve body and the brass female end is used to insert the seals into the valve body.
12. To restuff a valve body first take the end ring, (the plastic or brass ring without holes), then with your thumb press the button on the brass sleeve end, the large dia. inner portion is now exposed. (See Fig. 4.) Place the end ring on this pilot with the lip on the end ring facing the tool, and push the tool into the valve body bore until it bottoms. While the tool is in the valve body take a seal and press it into the inside diameter of the exposed brass female end. (See Fig. 5.)
13. Remove the tool, turn it end for end and insert it into the valve body bore. While holding the large dia. of the tool, slide it all the way into the valve body bore until it bottoms, then push the center button to push the seal out of the tool and leave it in place in the valve body. (See Fig. 6.)
14. Remove the tool from the valve body and push the center on the brass female end to expose the pilot on the opposite end. Place a spacer on this end and insert the spacer and tool into the valve.

# MODEL 2500 ECONOMINDER®

## Seal and Spacer Replacement (Cont'd.)

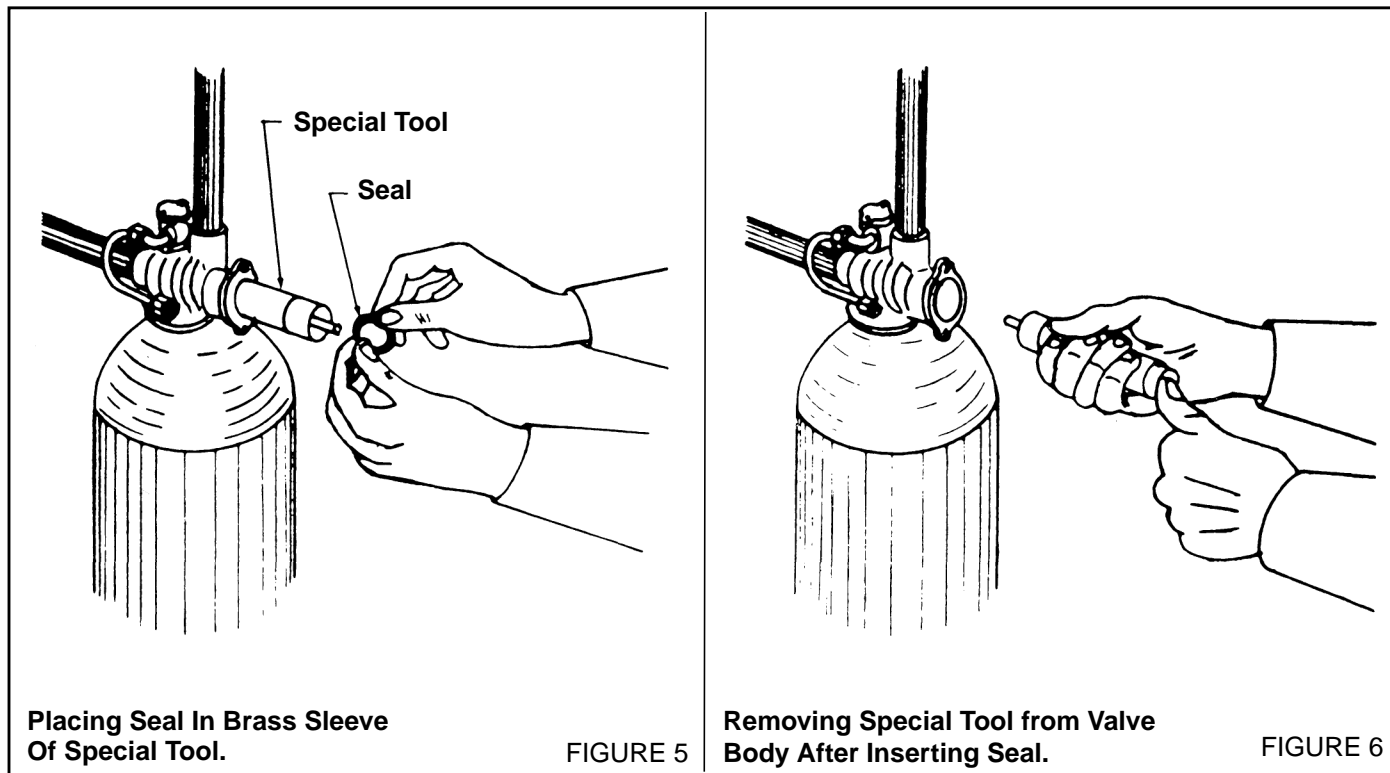

15. While the tool is still in the valve, press another seal into the inside diameter of the exposed brass sleeve end.
16. Remove the tool, turn it end for end, and insert it into the valve body bore.
17. Alternately repeat steps No. 13 and 14 until all seals and spacers have been pushed into the valve. (See valve cross section of your valve.)
18. Place silicone lubricant on the piston and inside the valve.
19. Hold the back plate with one hand and guide the piston into the valve body with the other hand, then grasp the back plate on both sides and slowly push the piston assembly and end plug assembly into the valve. (See Fig. 1.)
20. Replace the two capscrews to hold the back plate to the valve and tighten securely.
21. Connect the brine line from the injector housing to the brine valve, (if your unit has timed brine tank fill).
22. Set the time of day dial to the correct time.
23. Replace the electrical plug in the outlet.
24. Turn on water supply.
25. Cycle control and check for proper function.
26. Check by-pass valve.

# MODEL 2500 ECONOMINDER®

## *Piston Assembly Replacement*

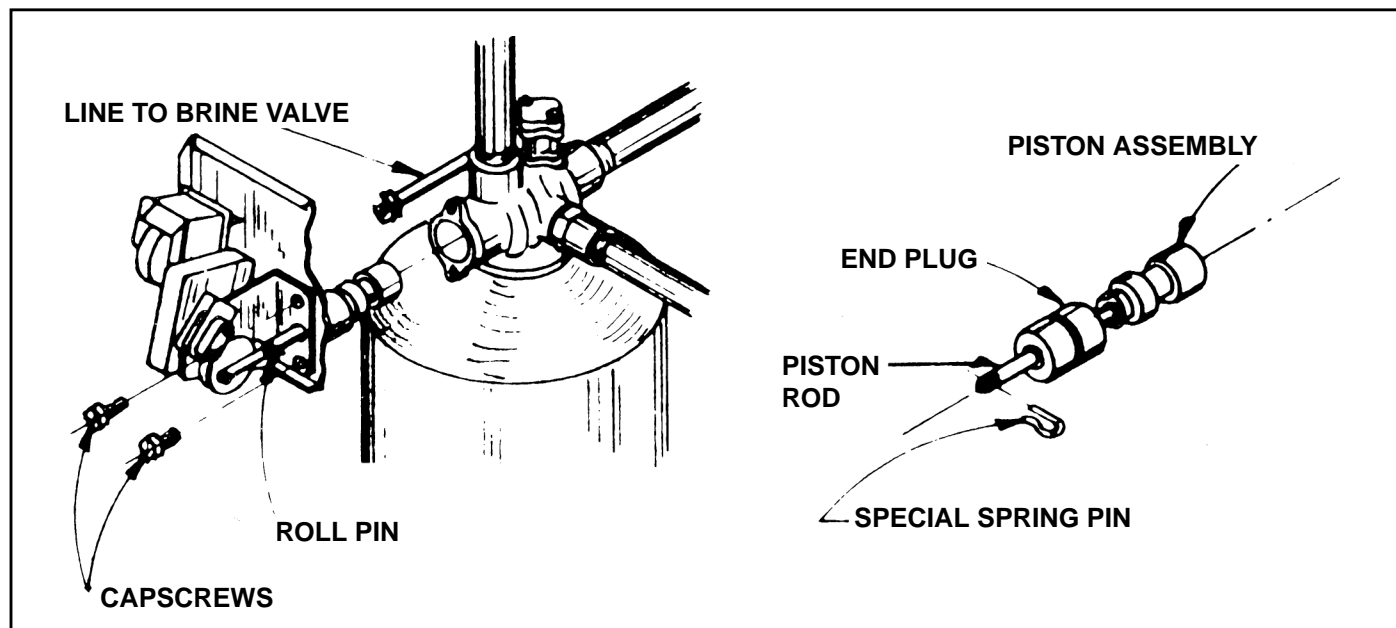

1. Turn off water supply to the valve and relieve water pressure.
2. Cycle the valve until the piston is in the service position (piston rod all the way out).
3. Remove electrical plug from outlet.
4. Remove two capscrews holding back plate to valve.
5. Disconnect brine line, from injector housing to brine valve, at the brine valve (if your unit has timed brine tank fill).
6. Grasp the back plate on both sides and slowly pull end plug and piston assembly out of the valve body.
7. Pull out the roll pin or special spring pin that connects the piston rod to the connecting link and remove the complete end plug and piston assembly.
8. Take the new piston assembly as furnished, pass thru the back plate and motor support and fasten piston rod to the connecting link with special spring pin.
9. Inspect the inside of the valve to make sure that all seals and spacers are in place.
10. Spread or spray silicone lubricant on the piston and on the seals inside the valve body.
11. While holding the back plate on the side with one hand, start the piston into the valve by guiding it with the other hand. Then grasp the back plate on both sides and slowly push the piston and then the end plug into the valve.
12. Replace the two valve body capscrews and tighten.
13. Connect the brine line to the brine valve, if used.
14. Place electrical plug in outlet.
15. Set time of day.
16. Turn on water supply.
17. Cycle control and check for proper function.
18. Make sure that valve is in service position (piston rod all the way out).
19. Check by-pass valve.

# MODEL 2500 ECONOMINDER®

## Typical Top Mounting Installation

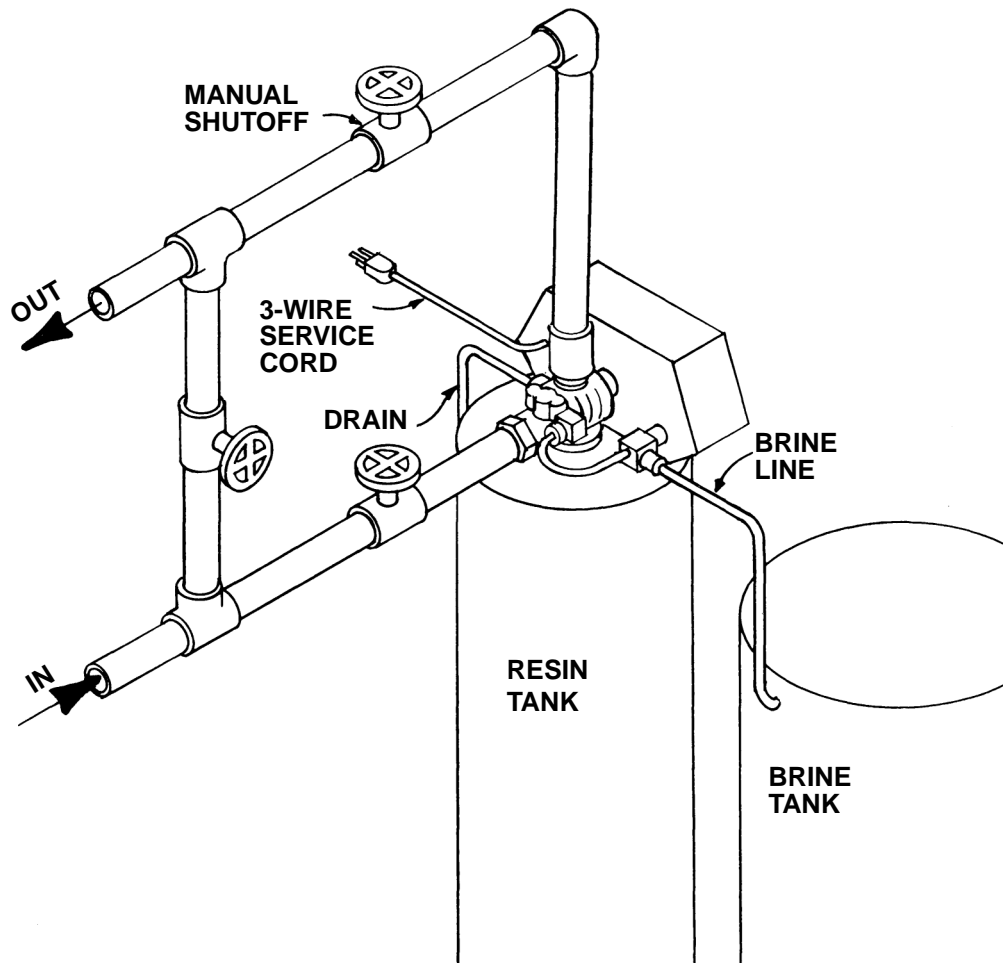

### TYPICAL CONTROL VALVE INFORMATION

Tank Size Dia.	Injector	Slow Rinse Rate (gpm) @ 40 PSI	Brine Draw Rate (SPM) @ 40 PSI	B.L.F.C. <sup>1</sup>	D.L.F.C. <sup>2</sup>
6"	#0 Red	.31 gpm	.28 gpm	.5 gpm	1.2 gpm
7"		.31 gpm	.28 gpm	.5 gpm	1.2 gpm
8"	#1 White	.45 gpm	.38 gpm	.5 gpm	1.5 gpm
9"		.45 gpm	.38 gpm	.5 gpm	2.0 gpm
10"		.45 gpm	.38 gpm	.5 gpm	2.4 gpm
12"	#2 Blue	.84 gpm	.56 gpm	1.0 gpm	3.5 gpm
13"		.84 gpm	.56 gpm	1.0 gpm	4.0 gpm
14"	#3 Yellow	1.0 gpm	.63 gpm	1.0 gpm	5.0 gpm
16"		1.0 gpm	.63 gpm	1.0 gpm	7.0 gpm

Note: Due to varying water conditions, tank sizes and water pressures, the above settings should be used only as a guideline.

<sup>1</sup>B.L.F.C. (Brine Line Flow Control). Refill Rate for Filling Brine Tank.

<sup>2</sup>D.L.F.C. (Drain Line Flow Control). Backwash and Rapid Rinse Flow Rates.

# MODEL 2500 ECONOMINDER®

## Wiring Diagram for Valve Drive Motor and Timer

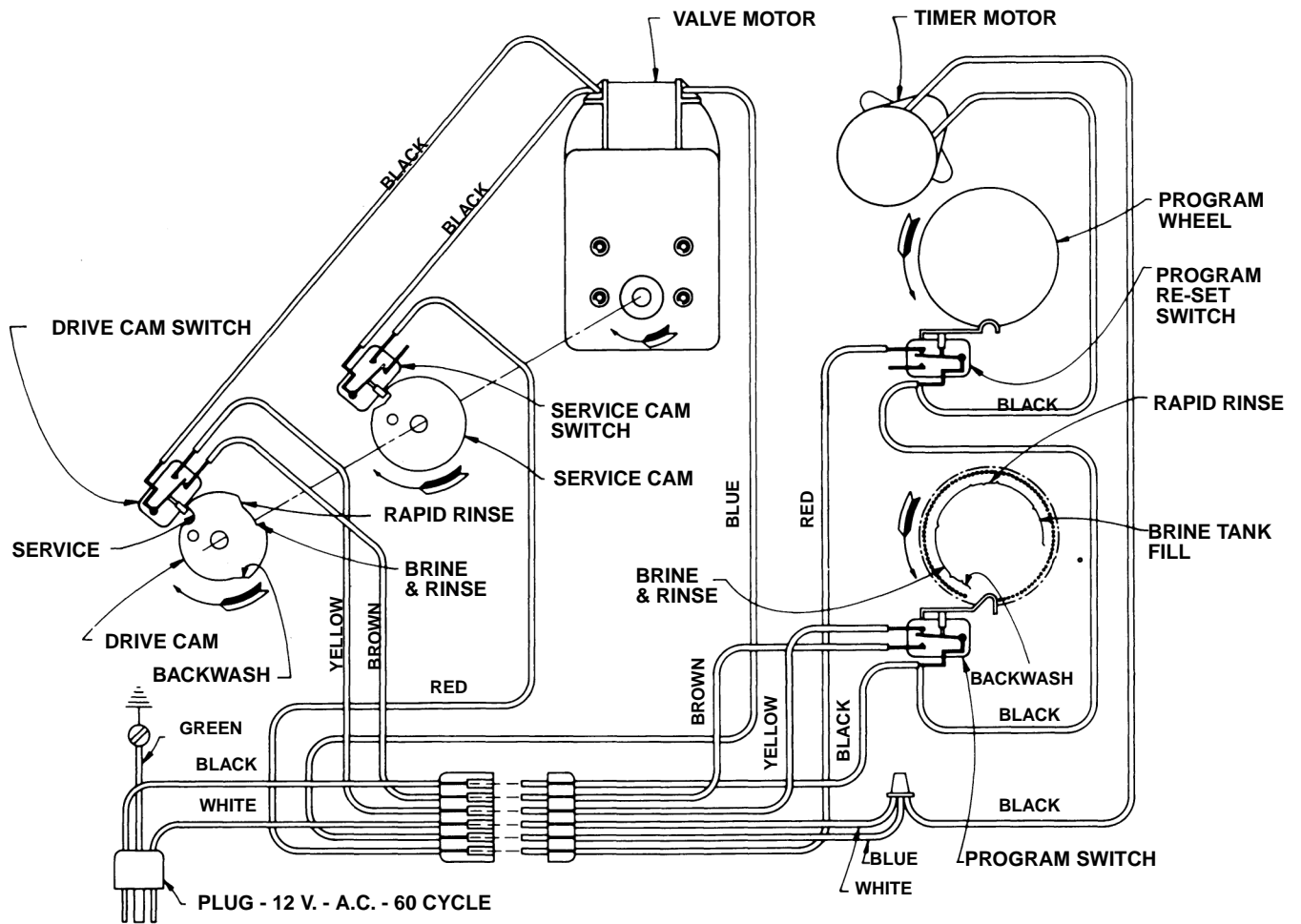

# MODEL 2500 ECONOMINDER®

## Service Assemblies

<b>60020-25</b> . . . . . <b>BLFC .25 GPM</b>	<b>60122</b> . . . . . <b>Seal and Spacer Kit, Hot Water</b>
<b>60020-50</b> . . . . . <b>BLFC .50 GPM</b>	6 . . . . .10545 . . . . .Seal, Piston, Hot Water
<b>60020-100</b> . . . . . <b>BLFC 1.0 GPM</b>	1 . . . . .10757B . . . . .End Spacer, Hot Water
For illustration, See Page 15	5 . . . . .16589 . . . . .Spacer, 12 Hole, Hot Water
<b>60029</b> . . . . . <b>1600 Brine Valve</b>	<b>60050</b> . . . . . <b>2500/2750 Drive Assy, STF 120V</b>
For Illustration, See Page 15	For Illustration, See Page 8
1 . . . . .10249 . . . . .Brine Valve Spring	2 . . . . .10218 . . . . .Micro Switch
1 . . . . .10250 . . . . .Retaining Ring	1 . . . . .10250 . . . . .Retaining Ring
2 . . . . .10329 . . . . .3/8" Brass Nut	2 . . . . .10302 . . . . .Insulator, Limit Switch
2 . . . . .10330 . . . . .3/8" Ferrule	2 . . . . .10338 . . . . .Pin, Roll 3/32 x 7/8
2 . . . . .10332 . . . . .3/8" Sleeve	1 . . . . .10621 . . . . .Link, 2500
1 . . . . .11749 . . . . .B/V Stem Guide	1 . . . . .10769 . . . . .Motor, Drive 110V 60HZ
1 . . . . .11982 . . . . .O-Ring Brine Valve	1 . . . . .10774 . . . . .Bracket, Motor Drive Side
1 . . . . .12552 . . . . .1600 Brine Valve Stem	5 . . . . .10872 . . . . .Screw, Hex Washer 8-32 x 5/16
1 . . . . .12626 . . . . .Shut Off Valve Seat	1 . . . . .11667 . . . . .Wire Harness, Drive Motor
1 . . . . .12748 . . . . .Brine Valve Body	1 . . . . .11826 . . . . .Bracket, Sensor Motor
1 . . . . .12550 . . . . .Quad Ring	1 . . . . .12576 . . . . .Cam, Drive STF
<b>60080</b> . . . . . <b>1600 Injector Assembly</b>	1 . . . . .12777 . . . . .Cam, Shut-Off Valve
For Illustration, See Page 10	1 . . . . .13366 . . . . .Bearing, Drive 2500
1 . . . . .10227 . . . . .Injector Screen	2 . . . . .14923 . . . . .Screw, Pan HD Mach 4-40 x 1
1 . . . . .10228 . . . . .Injector Cap	1 . . . . .17904 . . . . .Bushing, Heyco 1/2
1 . . . . .10229 . . . . .Injector Cover Gasket	<b>60306-XX</b> . . . . . <b>Timer, 3210 Delay</b>
1 . . . . .10328 . . . . .90° Elbow 1/4" NPT x 3/8 Tube	<b>60307-XX</b> . . . . . <b>Timer, 3220 Timed</b>
2 . . . . .10692 . . . . .Screw	See Parts Price List
1 . . . . .10913 . . . . .Injector Nozzle	<b>60135-2500</b> . . . . . <b>Service Repair Kit</b>
1 . . . . .10914 . . . . .Injector Throat	See Parts Price List
1 . . . . .11475 . . . . .Injector Body Gasket	<b>60085</b> . . . . . <b>Meter, 3/4" Std Range</b>
1 . . . . .12083 . . . . .Injector Body	<b>60387</b> . . . . . <b>Meter, 3/4" Ext Range</b>
<b>60090</b> . . . . . <b>Piston Assembly</b>	For Illustration, See Page 14
For Illustration, See Page 10	
1 . . . . .10209 . . . . .Quad Ring, -010	
1 . . . . .10234 . . . . .O-Ring, -024	
1 . . . . .10598 . . . . .End Plug Assembly	
1 . . . . .10909 . . . . .Pin, Link	
1 . . . . .15168 . . . . .Piston 2500	
1 . . . . .14452 . . . . .Piston Rod, 2500	
1 . . . . .14309 . . . . .Retainer, Piston Rod	
<b>60091</b> . . . . . <b>Piston Assembly, Hot Water</b>	
For Illustration, See Page 10	
<b>60121</b> . . . . . <b>Seal and Spacer Kit</b>	
6 . . . . .10545 . . . . .Seal, Piston	
1 . . . . .10757 . . . . .End Spacer, Noryl	
5 . . . . .11451 . . . . .Spacer, 12 Hole	



---

*Notes*

---

---

*Notes*

---

---

*Notes*

---

